

HMI-GL043 Series

FEATURES

- **16.77m (24 Bits) True Color**
- **32-Bit 800 MHz ARM RISC CPU**
- **Real-Time Clock, Reserve Time for More than 2 Years at Power Off State**
- **2 COM Ports, Supports Simultaneous Communications, Supports RS232/RS485/RS422**
- **24 VDC Input Voltage**
- **CE Certified**
- **128MB NAND FLASH + 128MB DDR3 Memory**
- **Ethernet Models Available**



DESCRIPTION

The Green Series GL043 is the most modern and powerful HMI product that will make your application work seamlessly, without missing a step. The GL043 Series has a new structure and elegant body, compared to previous HMI's. This HMI line comes with a 16.77 million Color Display mode that gives your touch screen rich color and incomparable resolution. The Green Series products use the most advantageous ARM Cortex-A7 architecture industrial-grade processors, which ensure that the HMI's work efficiently. Each HMI supports simultaneous communications via its multiple serial ports, so that you can connect to different controllers and PLCs at the same time. With the simple, convenient and powerful DTools configuration software, the user can master its design method and create first-class programs efficiently.

DIMENSIONS

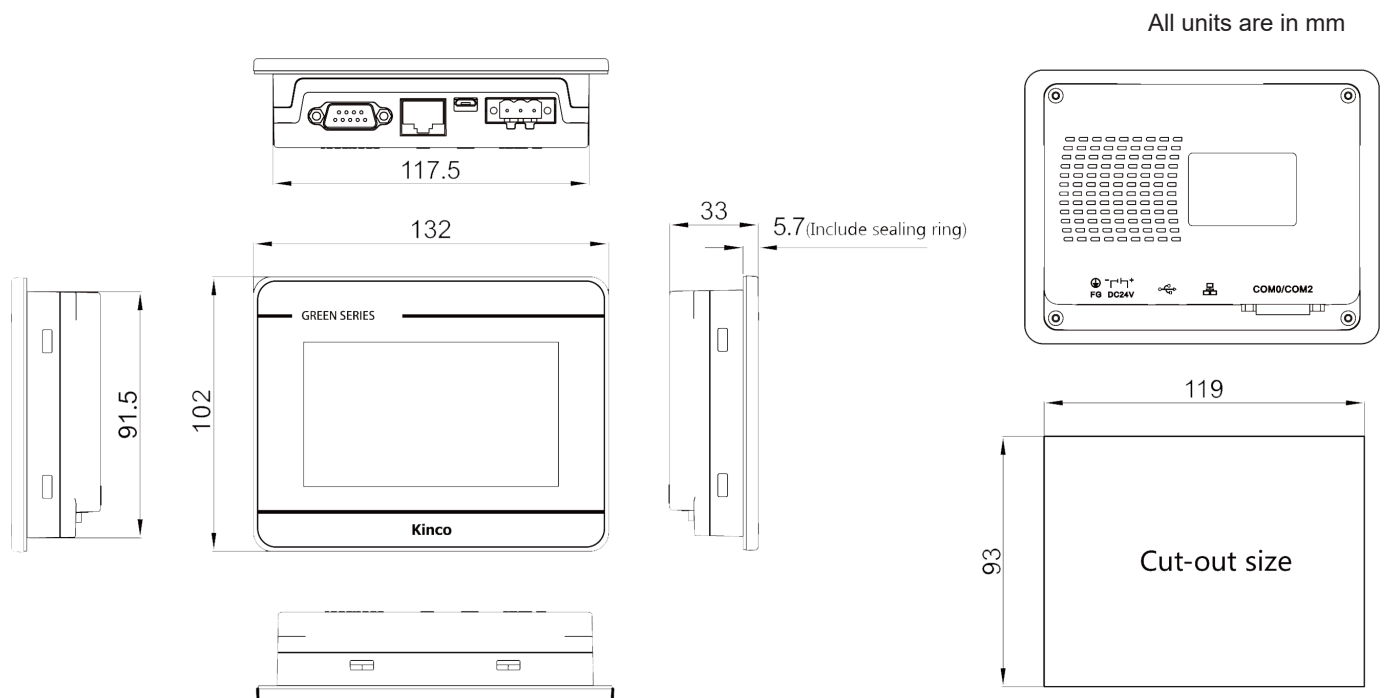

L011786

MODEL	GL043	GL043E
Display	4.3" TFT	
Display Area	95.04 (W) x 53.86 (H) (mm)	
Resolution	480x272 pixels	
Display Color	16.77 Million True Color	
Display Angle of View	70/70/50/70(left/right/up/down)	
Contrast Ratio	500:1	
Backlight	LED	
Brightness	450cd/m2	
Backlight Life	30000 Hours	
Touch Panel	4 Wire Precision Resistance Network (Surface Hardness 4H)	
CPU	ARM RISC 32Bit 800MHz	
Storage	128MB NAND Flash Memory + 128MB DDR3 Memory	
RTC	Built-in	
Expandable Memory	None	
Print Port	Series Port	
Ethernet	None	10/100MHz Adaptable Ethernet Interface
Program Download	USB Slave Micro / USB Flash Drive	USB Slave Micro / USB Flash Drive / Ethernet
Communication Port	COM0:RS232/RS485/RS422; COM2:RS232	
Input Power Supply	DC10V ~ DC28V	
Power Input	2W@24VDC	
Allowable Loss of Power	<3ms	
Insulation Resistance	Over 50MΩ@500VDC	
Hi-pot Test	500 VAC 1 Minute	
Shell Material	Engineering Plastic	
Shape Size	154 x 89 x 60 (mm)	
Installation Hole Size	146 x 81 (mm)	
Weight	0.46 lbs	
Working Temperature	0 ~ 50°C	
Working Humidity	10 ~ 90%RH (non-condensing)	
Storage Temperature	-20 ~ 60°C	
Storage Humidity	10 ~ 90%RH (non-condensing)	
Vibration Test	10 ~ 500Hz (X, Y, Z direction 2G/30 minute)	
Cooling Mode	Natural Air Cooling	
Panel Protection Grade	EN6100-6-4:2007,EN61000-6-2:2005	
Software	Kinco DTools V3.2 and Above	

1. Installation Note

1.1 Environment Requirement

Operating temperature: GL043/GL043E HMI can work stably in most industrial environments when the temperature is between 32°F to 122°F (0~50°C)

NEMA rating: HMI front panel is NEMA1 rated.

Do not install this HMI in the following environments:

- Areas with direct sunlight
- Environments where the surrounding temperature or humidity exceed specifications
- Areas with high condensation. Avoid areas where temperature changes dramatically or sharply, as these changes can cause condensation
- Areas with corrosive or combustible gas
- Environments where dust, dirt, salt, or iron powder are present
- Avoid water, oil, and vapor
- Areas in which the HMI will be subject to vibration or shock

Take shielding measures in the following locations:

- Anywhere electrostatic noise or electromagnetic noise is present
- Any location where X-rays or microwaves are present
- Near power sources

1.2 Power Requirement

- Input Voltage: DC10V~DC28V
- Maintain sufficient distance between the HMI and any converters or switching mode power supplies. Ensure that the input and output cables of such equipment are shielded cables, and that the shielding network is properly connected to ground.
- Ensure that the DC power and AC power are isolated

Note: An internal fuse will prevent damage for over-voltage, but does not guarantee protection against damage of internal electronic components.

2. Installation Description

2.1 Dimensional Drawing

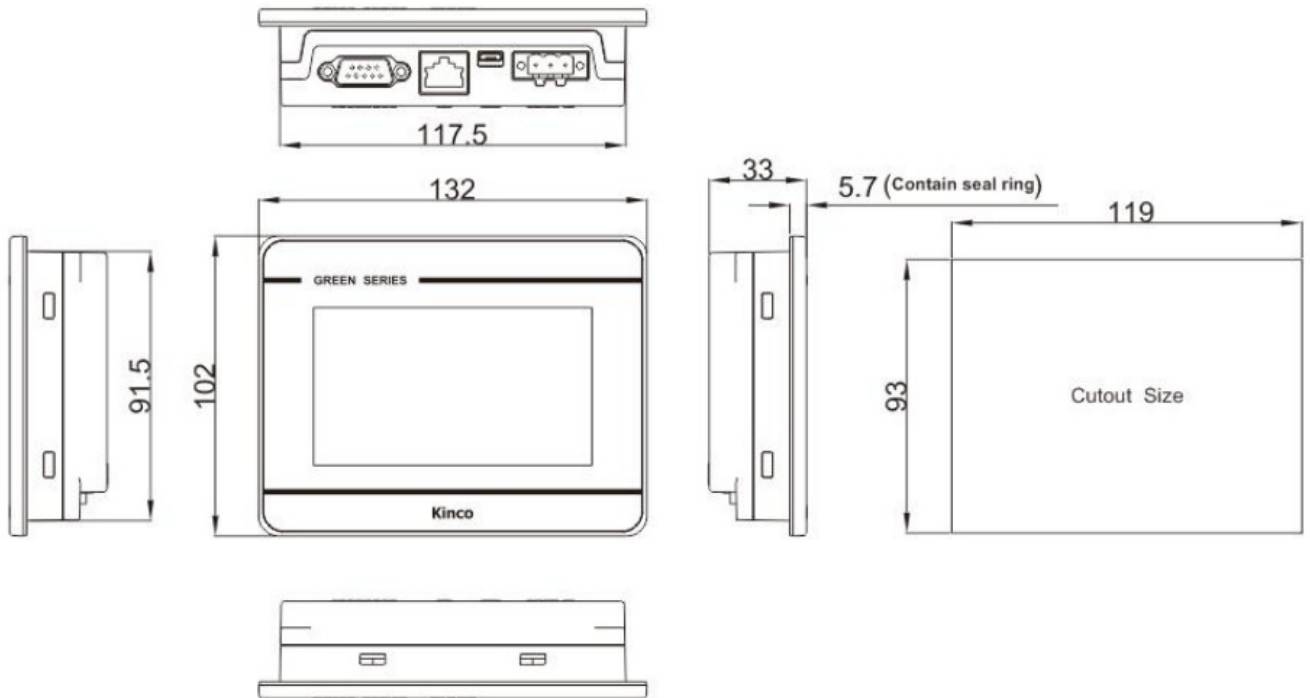

All units are in mm

2.2 Fixed Screw Installation Instructions

The product is placed into the cut out of the machine control box's panel, and the mounting screws are inserted into the fixing holes around the HMI shell from the back of the control box's panel. Recommended lock torque: 0.5N.m (for waterproof effect and to avoid shell deformation)

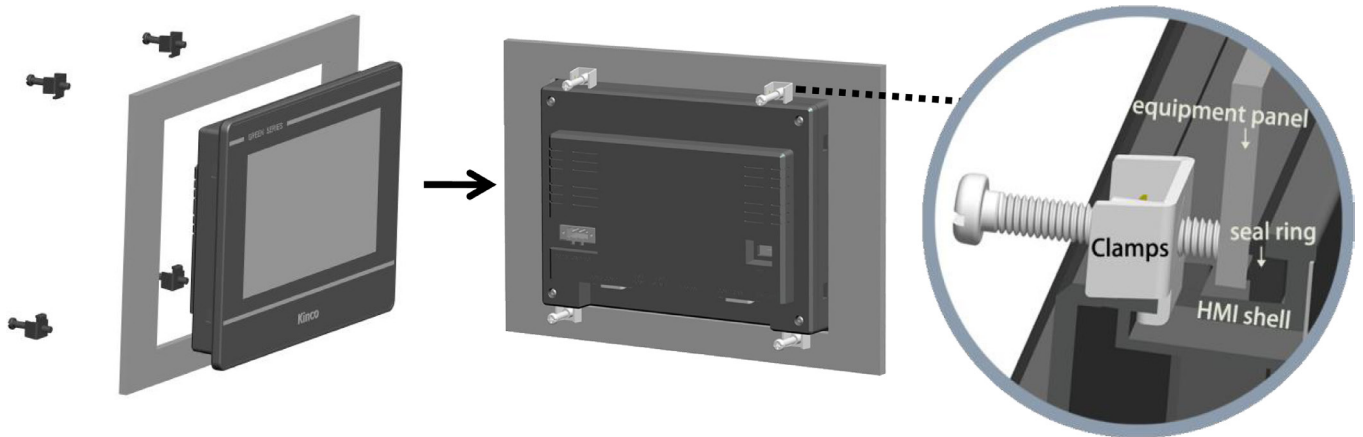

2.3 Power Connection

Before connecting the power, please make sure all local and national electrical standards are met. For power cables, please select cables with their dielectric strength values and current values in compliance with the safety specifications. First, find the power terminal at the back of the product and loosen the screw, by turning it counterclockwise. Then, insert the power cables and tighten the screw. Connect positive DC line to the 'DC24V' terminal, the DC ground to the 'GND' terminal and the earth or machine ground line to the 'FG' terminal.

3. External Interface

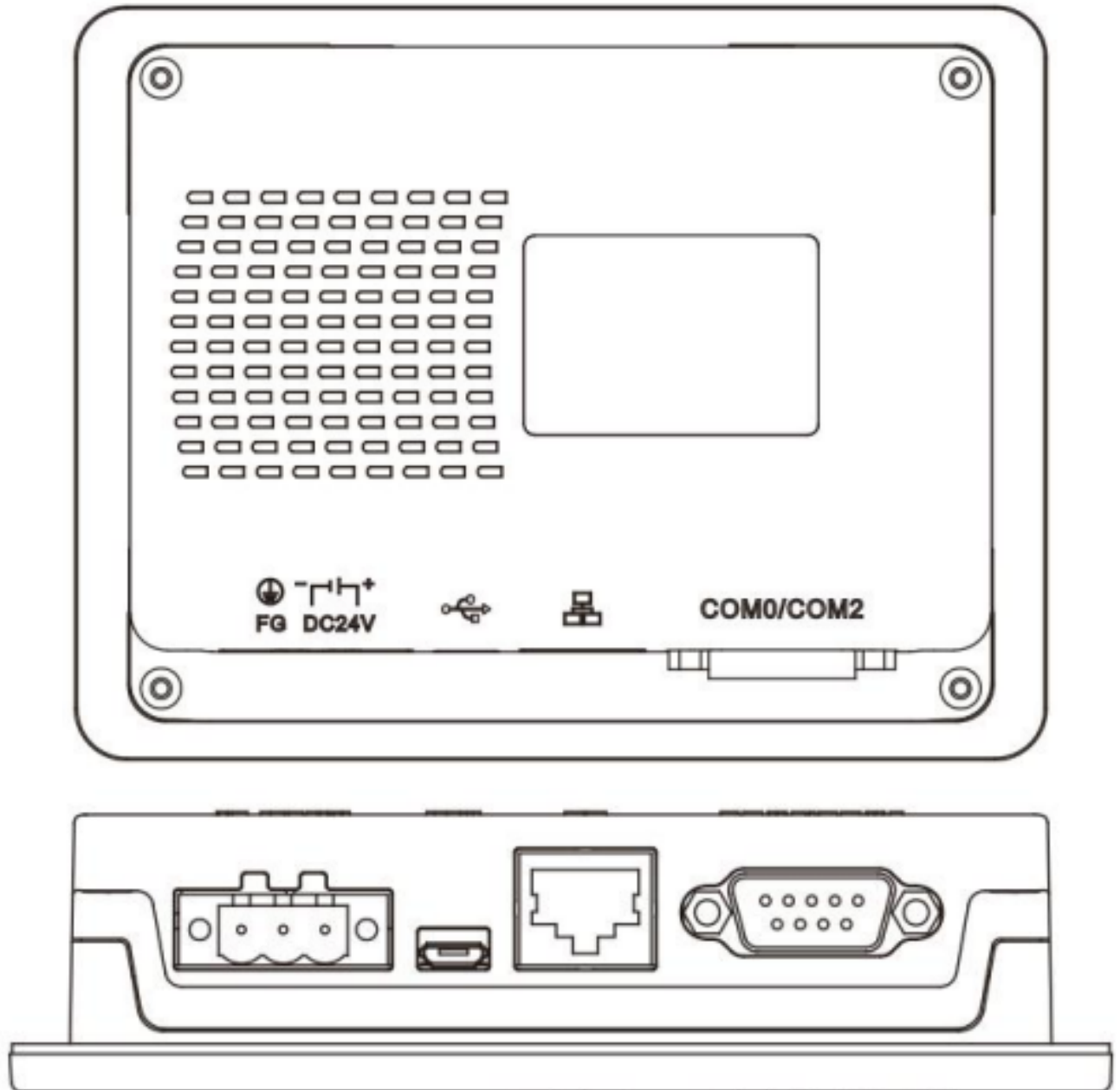

3.1 USB SLAVE

The interface type is MicroUSB

Connection	USB Slave port can be connected with a PC.
Port Function	The port is only used to download the user configuration program to the HMI and to set HMI system parameters.

3.2 Ethernet (Only GL043E support)

10M/100M adaptive Ethernet RJ45 port

Connection	With CAT5 UTP cable connected to the Ethernet device.
Port Function	The port can be used for upload/download of HMI configuration, setting of system parameters and online simulations of configurations. It can connect multiple HMIs via the Ethernet to form an HMI network. Furthermore, it can implement communications between the HMI and PLC via the Ethernet, as well as communications with a PC via the Ethernet port.

3.3 COM0/COM2

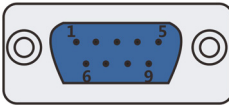

Pin assignment of the 9-pin male, D-SUB, COM0/COM2. Note: RS232/485/422 communication functions are supported by COM0. COM2 supports RS232 communication function.

Pin	Signal	PLC (COM0) [RS-422]	PLC (COM0) [RS-485]	PLC (COM0) [RS-232]	PC/PLC (COM2) [RS-232]
1	Rx- (B)	RS422 R-	RS485 B		
2	RxD_PLC			RS232 RxD	
3	TxD_PLC			RS232 TxD	
4	Tx-	RS422 T-			
5	GND	Signal Ground			
6	Rx+ (A)	RS422 R+	RS485 A		
7	RxD_PC				RS232 RxD
8	TxD_PC				RS232 TxD
9	Tx+	RS422 T+			